

APPLICATIONS

Fire and general service pumps

Bilge and ballast pumps

Emergency fire pumps

Other use

GENERAL CHARACTERISTICS (SINGLE SUCTION)

Item	Model	SVB 65	SVB 100	SVB 125
Rotation		Clockwise when viewed from the driver		
Suction bore	(mm)	65	100	125
Discharge bore	(mm)	65	100	125
Stuffing box seal		Gland packing or Mechanical seal		
Max.output	(kW)	15	30	75
weight:CAC	(kg)	165	185	255
weight:FC	(kg)	150	165	230
Water filled in casing	(kg)	4	6	18



SVB 65-125

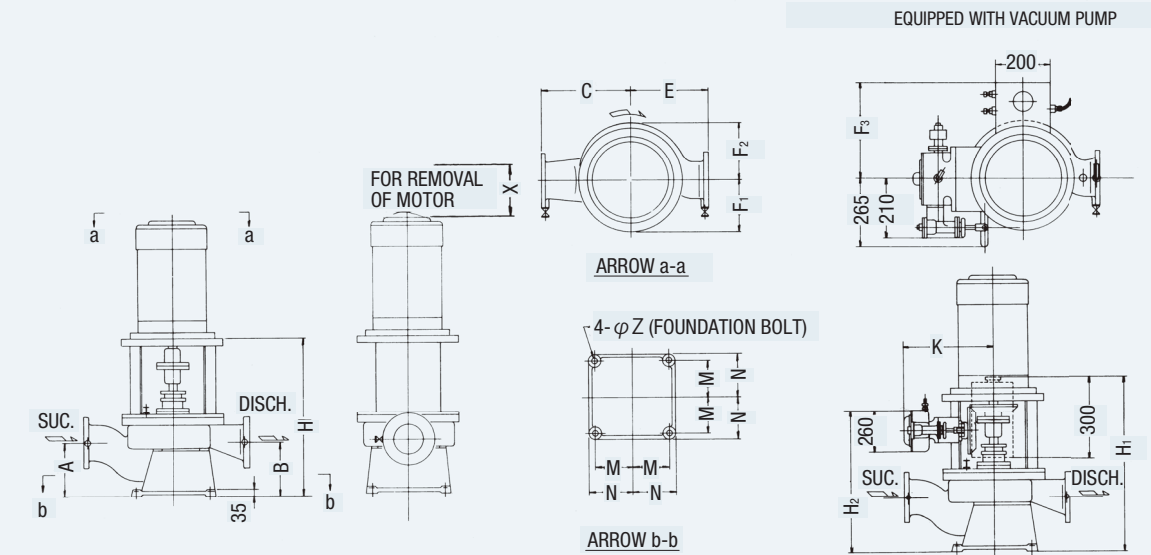

Dimensions:mm

Model	A	B	C	E	F ₁	F ₂	F ₃	H	H ₁	H ₂	K	M	N	X	Z	Mecha. seal
SVB 65	150	150	280	250	133	165	350	554	654	594	420	125	150	170	23	30
SVB 100	180	180	300	270	220	220	350	609	689	629	420	170	195	170	25	35
SVB 125	190	190	380	320	255	255	460	700	800	750	500	170	195	200	25	45

APPLICATIONS

Fire and general service pumps

Bilge and ballast pumps

Emergency fire pumps

Other use

GENERAL CHARACTERISTICS (DOUBLE SUCTION)

Item	Model	SVB 150	SVB 200
Rotation		Clockwise when viewed from the driver	
Suction bore	(mm)	150	200
Discharge bore	(mm)	150	200
Stuffing box seal		Gland packing or Mechanical seal	
Max.output	(kW)	110	150
weight:CAC	(kg)	320	410
weight:FC	(kg)	280	360
Water filled in casing	(kg)	42	62



SVB 150-200

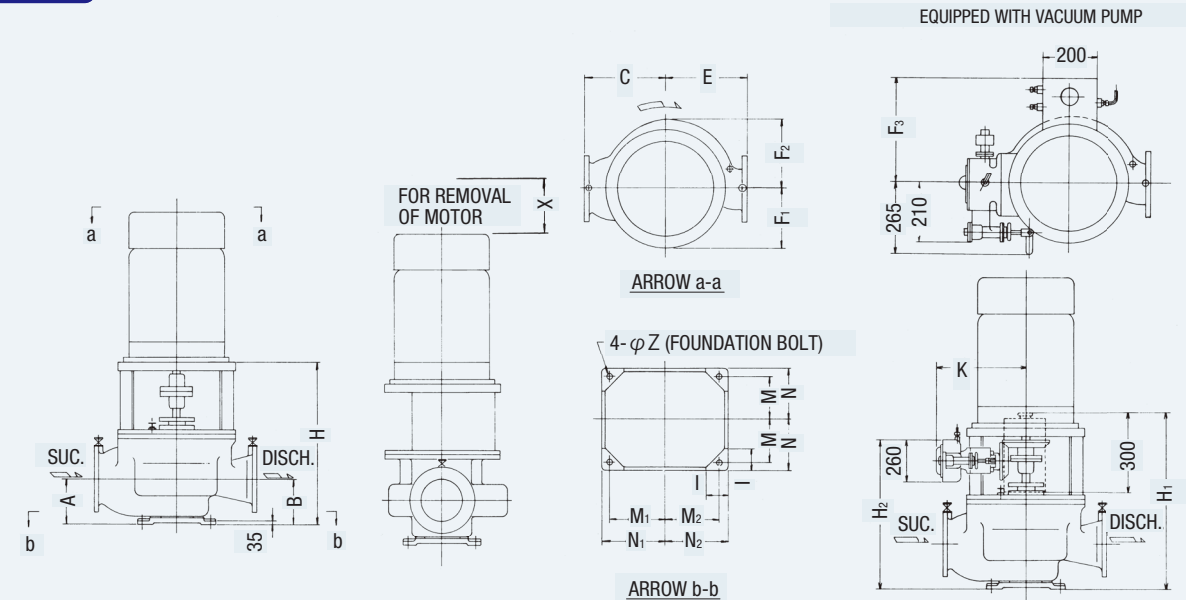

Dimensions:mm

Model	A	B	C	E	F ₁	F ₂	F ₃	H	H ₁	H ₂	I	K	M	M ₁	M ₂	N	N ₁	N ₂	X	Z	Mecha. seal
SVB 150	240	240	380	380	310	310	555	780	880	820	90	500	180	240	180	210	270	210	200	27	45
SVB 200	300	300	450	450	365	365	600	900	1000	940	110	540	200	275	200	230	305	230	200	33	55

PERFORMANCE CHARTS

