

APPLICATIONS

Condensate pumps

Drain transfer pumps

Other use



GENERAL CHARACTERISTICS

Item	Model	RVE 70	RVE 100	RVE 130
Rotation		Clockwise when viewed from the driver		
Suction bore	(mm)	125	200	250
Discharge bore	(mm)	65	100	125
Balance pipe	(mm)	25		
Stuffing box seal		Gland packing or Mechanical seal		
Max.output	(kW)	7.5	18.5	22
weight:FC	(kg)	175	288	358
Water filled in casing	(kg)	10	28	29

RVE 70~130

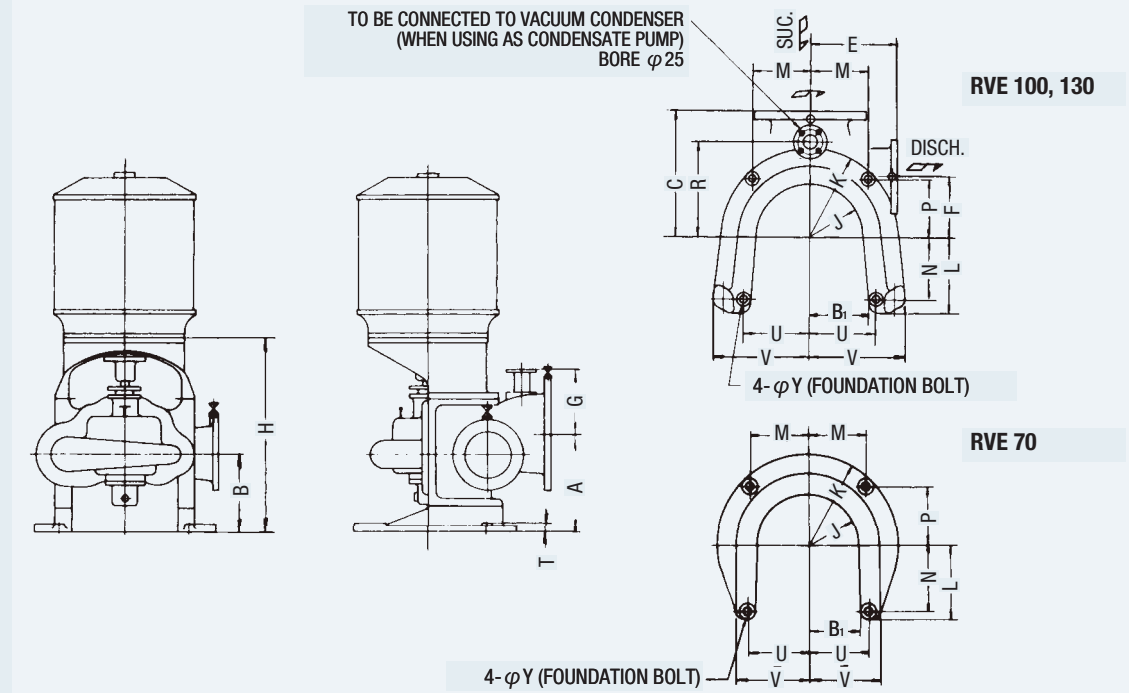

Dimensions:mm

Model	A	B	C	E	F	G	H	J	K	L	M	N	P	R	T	U	V	Y	B ₁	Mecha. seal
RVE 70	285	190	330	250	170	185	564	155	270	225	170	200	170	265	50	180	201	23	159	35
RVE 100	360	230	380	330	200	250	693	190	310	260	200	225	200	300	50	210	335	27	184	50
RVE 130	360	230	380	330	200	250	693	190	310	260	200	225	200	300	50	210	335	27	184	50

PERFORMANCE CHART

