

APPLICATIONS

- Main condensate pumps
- Drain transfer pumps
- Other use

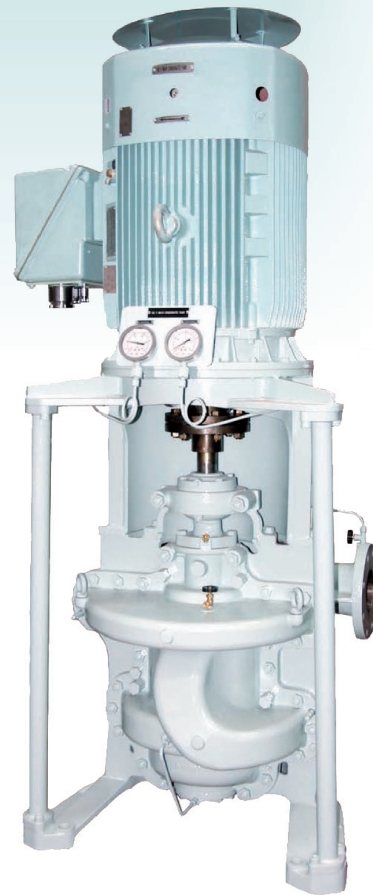

GENERAL CHARACTERISTICS

Item	Model	EVZ 50	EVZ 70	EVZ 100	EVZ 130	EVZ 130-2	EVZ 150
Rotation		Clockwise when viewed from the driver					
Suction bore (mm)		100	125	200	250	250	300
Discharge bore (mm)		50	65	100	125	125	150
Stuffing box seal		Gland packing or Mechanical seal					
Max.output (kW)		22	22	45	55	90	150
weight:FC (FCD) (kg)		200	470	530	590	640	760
Water filled in casing (kg)		7	24	27	48	58	68

1st stage impeller : Single suction for EVZ 50, 70, and 100
Double suction for EVZ 130, 130-2, and 150

EVZ 50~150

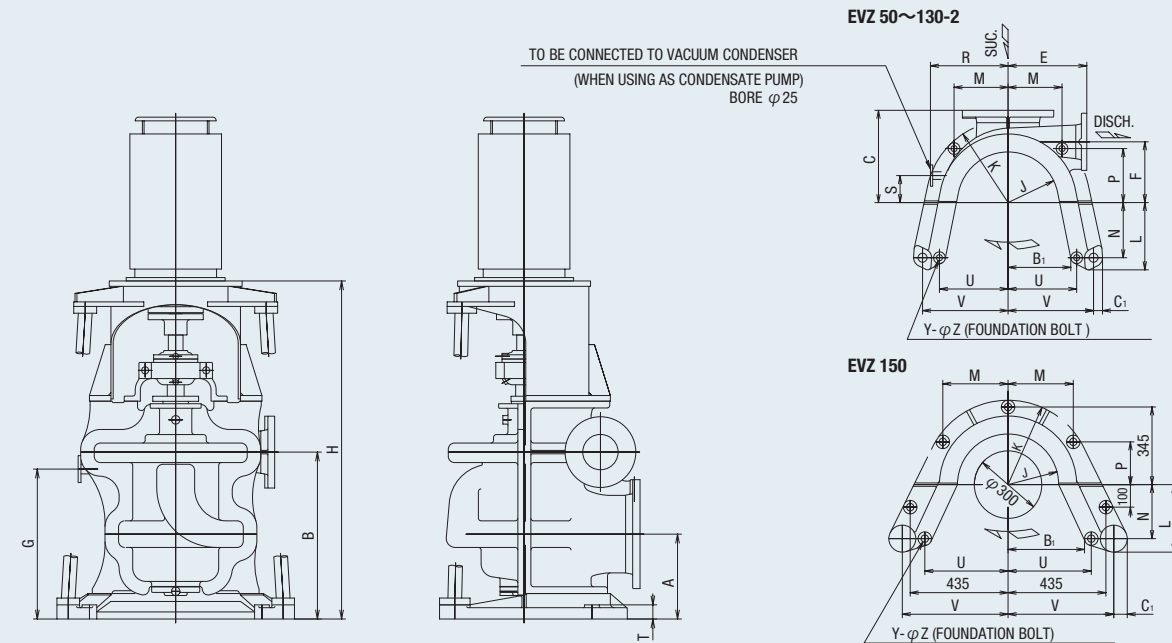

Dimensions:mm

Model	A	B	C	E	F	G	H	J	K	L	M	N	P	R	S	T	U	V	Y	Z	B ₁	C ₁	Mecha. seal
EVZ 50	210	310	260	260	120	270	739	155	270	235	170	200	170	200	150	50	180	260	4	23	159	50	35
EVZ 70	330	460	350	330	210	395	973	225	365	300	240	245	240	320	105	50	305	380	4	27	279	40	50
EVZ 100	350	490	350	330	210	440	1122	225	365	300	240	245	240	320	100	50	305	380	4	27	279	40	60
EVZ 130	300	590	410	350	270	530	1222	225	365	300	240	245	240	345	120	50	305	380	4	27	279	40	60
EVZ 130-2	300	590	440	380	320	525	1222	225	365	300	240	245	240	370	120	50	305	380	4	27	279	40	60
EVZ 150	325	670	460	380	345	585	1166	225	375	300	290	240	190	400	140	50	370	470	7	33	340	60	60

PERFORMANCE CHART

